

STOP WATER WASTE

Turn stormwater runoff into a quality water source

www.gea-2h.co.uk

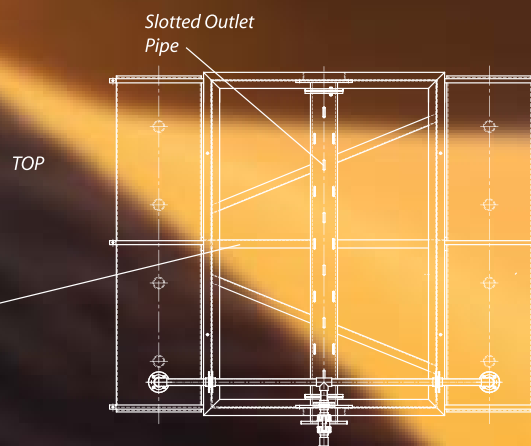

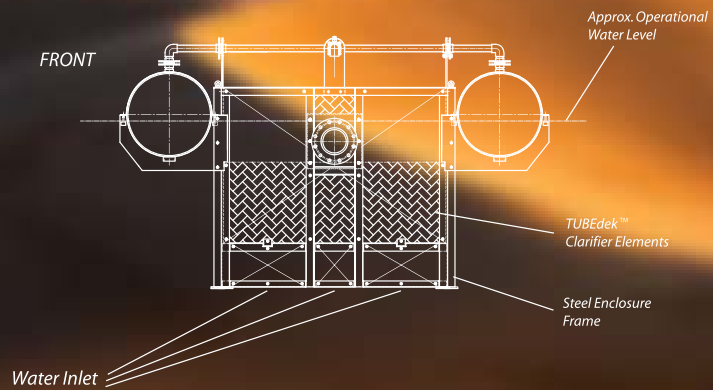
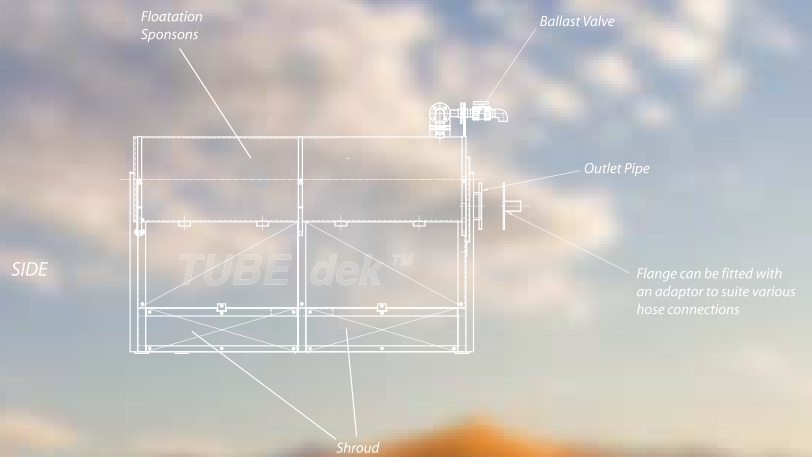
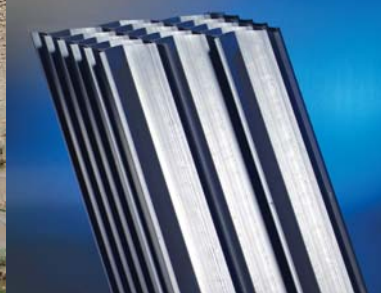

Stormwater is valuable

We need not waste this water!

Water is one of our most valuable resources
Huge volumes of rainwater fall in thunderstorms
This water mostly evaporates and is lost

What can be done

Can we save this water from evaporation?

GEA 2H has a Water Management System to collect, clean and store water
So that stormwater becomes usable water – for a variety of agricultural and industrial uses

What are the obstacles

Must work in this environment

- be resistance to weather extremes – sunlight, abrasion and cold temperatures
- have low levels of maintenance
- operate over sustained periods of time
- must be structurally sound and of proven technology
- mobility – go where the storms are
- deliver against stringent specification

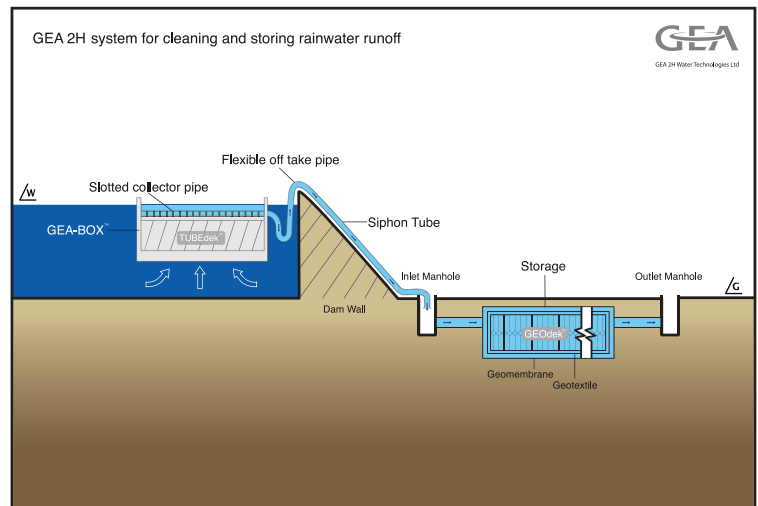

Now there is an alternative

Innovative adaption of proven technology to make stormwater usable
Addressing one of the most critical environmental issues

Stormwater Reclamation and Storage System

A temporary water storage system that holds excess surface water after periods of peak rainfall, then cleans it to strip out suspended solids and finally stores the clarified water

System comprises:

- GEA-BOX™ Portable Lamella Clarifier to remove suspended solid matter from stormwater runoff
- GEOdek™ Catchment Tank for controlled collection and storage of stormwater

What are the product credentials?

GEA 2H Water Technologies have developed water management equipment and installation concepts for the widest range of industrial applications. From wastewater treatment to industrial cooling and storm water control, GEA 2H have been designing and installing plastic media equipment throughout the world.

During their 30 years in business, GEA 2H Water Technologies has built an outstanding reputation for quality products and services and hold EN ISO 9001, TÜV and BBA accreditation.

Contact us

To talk through your project ideas or requirements – and understand more about how this innovative new solution could work for your next project.



GEA 2H Water Technologies Ltd

Ranik Ltd

Worldwide Distributors for GEA-BOX™
5 Barrington Court, Buckingham Industrial Estate,
Brackley, NN13 7PL, UK

Tel +44 (0)1 280 704 085
Fax +44 (0)1 280 841 932
Email sales@ranik-group.com
www.gea-2h.co.uk/stormwater

